

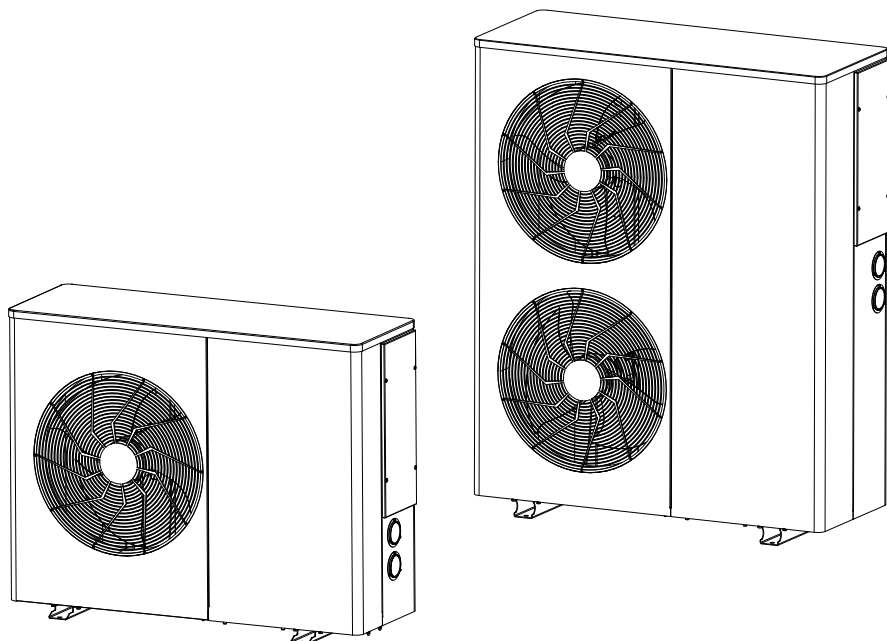

DC INVERTER Heat Pump



Installation Manual&User
Air to Water Heat Pump

FGS10MB / FGS20MB

Attention

Thank you for choosing our product, we shall be more than glad to service you. For you to better operate this product and to prevent accidents due to misuse, please read carefully this user manual before carrying out any installation or operation, also please pay special attention to the warning, prohibition and attention instructions. We are continuously supplementing and upgrading this user manual to better service for you!

CONTENTS

Installation Manual

Part 1. Before use

1. Atentions	2
2. Installation	4
3. R32 refrigerant introduction	4
4. Heat pump installation and wiring	9

User Manual

Part 2. User interface

• Buttons function	27
• Main mask	27
• User menu	29

Part 3. Maintenance and repairing

• Error code and repairing	37
• Other problem and repairing	38
	40

Part 1. Before Use



This appliance is not intended for use by persons, including children, with reduced physical, sensory or mental capabilities, or lack of experience and knowledge, unless they have been given supervision or instruction concerning use of the appliance by a person responsible for their safety; Children should be supervised to ensure that they do not play with the appliance.



Be sure to read this manual before use.

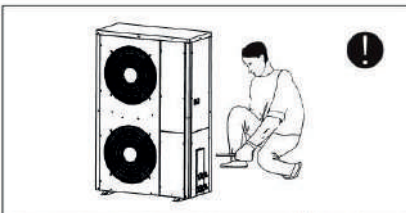

Be sure to read this manual before use. The installation, dismantle, maintenance of the unit must be performed by qualified personnel. It is forbidden to do any changes to structure of the unit. Otherwise injury of person or unit damage might happen.

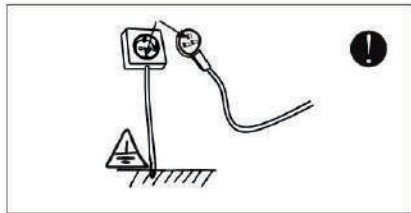

The power supply to the unit must be grounded.

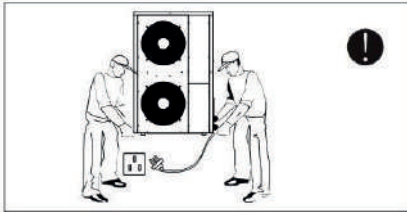

Make sure the power supply to the heat pump unit is off before any operations are done on the unit.
When the power cord gets loose or is damaged, always get a qualified person to fix it.

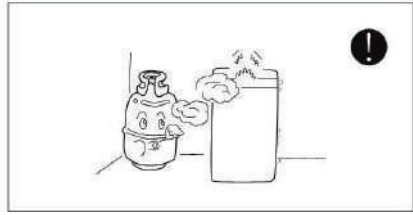

Keep the unit away from the combustible or corrosive environment.

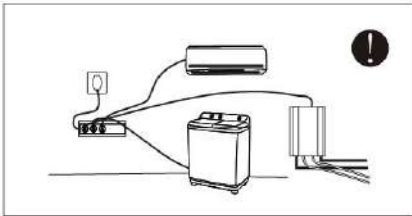

Use a dedicated circuit for this unit, otherwise malfunction may occur.

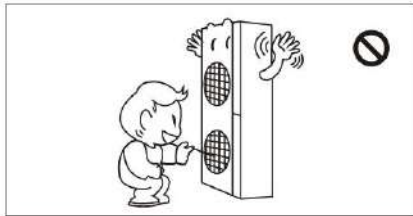

Do not touch the air outlet grill when fan is running.

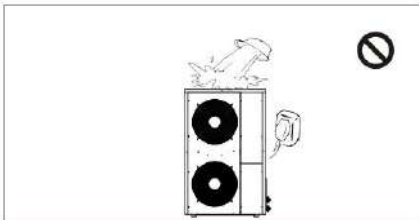

Water or any kind of liquid is strictly forbidden to be poured into the product, or may cause creepage or breakdown of the product.

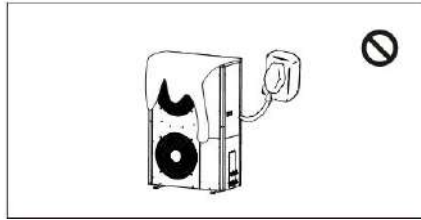

When running the unit, never cover with cloth or any other material that blocks ventilation on the product which will lead to low efficiency or even non-operation of this unit.

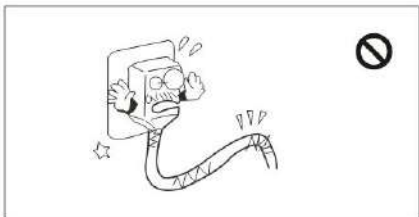

When the power cord gets loose or is damaged, always get a qualified person to fix it.

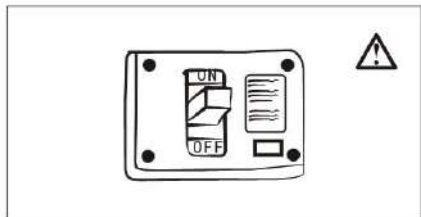

It is mandatory to use a suitable circuit breaker for the heat pump and make sure the power supply to the heater corresponds to the specifications. Otherwise the unit might be damaged.



Warning



Caution



Prohibited

Safety precaution

2. Installation safety

1. Installation should comply with local regulations and requirements.
2. Choose a suitable place for use (please refer to indoor/outdoor unit location selection). The cooling capacity/heating capacity of the heat pump should match with the size, height, and heat insulation of the room.
3. Before installation, check the correspondence of neutral line, ground line, A phase, B phase, C phase of the user power supply as well as the lines of the heat pump.
4. This heat pump complies with the safety and operation standards issued by the country.
5. When the heat pump needs to be installed or moved this must be done by professional refrigeration installation and maintenance personnel. Heat pumps installed by non-professionals are prone to quality or safety problems.
6. The user should provide a power supply that satisfies the installation and use. The allowable range of voltage that can be used by this product is $\pm 10\%$ of the rated value. If this range is exceeded, it will affect the normal operation of the heat pump. If necessary, use a voltage stabilizer to avoid property damage.
7. The heat pump must have an independent power supply circuit. The independent circuit should be equipped with leakage protection and an automatic circuit breaker provided by the user.
8. The heat pump should be installed in accordance with the national wiring regulations.
9. The heat pump must be grounded correctly and reliably, otherwise it may cause electric shock or fire.
10. Please do not turn on the power of the heat pump until the piping and wires are connected and checked

3. R32 refrigerant introduction

The heat pump uses environmentally friendly R32 refrigerant. This is a slightly flammable refrigerant. Although it can burn and explode under certain conditions, as long as it is installed in a room of the correct area and used correctly, there will be no danger of combustion and explosion. Compared with other refrigerants, R32 is an environment-friendly refrigerant that does not damage the ozone layer, and has low global warming potential.

R32 HEAT PUMP ROOM AREA REQUIREMENTS (FOR SPLIT TYPE HEAT PUMPS)

The area of the heat pump installation, operation and storage room should be larger than 4 square meters.

DO NOT INSTALL MONOBLOCK TYPE HEAT PUMPS IN CLOSED ROOMS.



1. Please read this manual before installation, operation and maintenance.
2. Except as specifically recommended by the manufacturer, please do not use any method to speed up the defrosting process or clean the frosted part.
3. Please do not damage the body of the heat pump and do not expose to ignition.
4. The heat pump should be stored in a room without any fire sources (such as gas appliances ignited by an open flame, electric heaters, etc.).
5. When repairs are required, please contact the nearest after-sales service centre. When repairing, you must strictly abide by the operation manual provided by the manufacturer. **Repair by non-professionals is forbidden.**
6. Please comply with the relevant national gas laws and regulations.
7. The refrigerant in the system needs to be recovered and removed during maintenance or disposal.



Repair of sealing elements

1. When repairing closed components, disconnect the power supply to the equipment before opening the sealed cover. If power supply is necessary during the maintenance process, continuous leak detection should be performed at the most critical points to avoid potentially dangerous situations.
2. In the following maintenance of electrical components, special care should be taken not to affect the protection level of the enclosure. Improper maintenance methods may cause: damage to cables, excessive connections, terminals not installed according to the original regulations, damage to the seal, incorrect installation of the sealing cover and other dangers. Ensure that the installation of the equipment is safe and reliable. Ensure that the sealing or sealing material will not lose its function of preventing the entry of flammable gas due to aging. Replacement parts should meet the manufacturer's specifications.

Note: The use of silicon-containing sealants may reduce the detection capabilities of leak detection equipment. Intrinsically safe components do not need to be isolated before operation.

Maintenance of intrinsically safe components

If it is not possible to ensure that the heat pump does not exceed the allowable voltage and current limits during use, do not use any permanent inductive or capacitive load in the circuit.

Intrinsically safe components are the only components that can continue to work in flammable gases.

Replacement of components should be only done with the parts specified by the manufacturer, other parts may cause refrigerant leak and fire risk.

Cable

Check whether the cable will be affected by wear, corrosion, overpressure, vibration, sharp edges or other adverse environments. The inspection should also consider the influence of aging or continuous vibration of the compressor and fan on the cable.

Leak inspection of R32 refrigerant

Check for refrigerant leakage should be done in an environment where there is no potential ignition source. Halogen probes (or any other detectors that use open flames) should not be used for detection.

Leak detection method

For systems containing R32 refrigerant, an electronic leak detector can be used for testing. The test should be calibrated in a refrigerant-free environment. Ensure that the leak detector does not become a potential source of ignition and is suitable for the refrigerant being tested. The leak detector should be set to the lowest flammable concentration of the refrigerant (expressed as a percentage), calibrated with the refrigerant used and adjusted to the appropriate gas concentration test range (up to 25%).

The fluid used to detect leaks is suitable for most refrigerants, but do not use chlorine-containing solvents to prevent chlorine and refrigerants from reacting and corroding copper pipes.

If a leak is suspected, remove any ignition source from the appliance area.

If welding is required at the location where the leakage occurs, all refrigerants should be recovered, or all refrigerants should be isolated away from the leakage point (use shut-off valves). Oxygen-free nitrogen (OFN) is used to purify the entire system before and during welding.

Remove refrigerant and vacuum

Maintenance or other operations on the refrigeration circuit should be performed in accordance with normal procedures. Safety should also be considered and the procedure should be followed:

1. Remove refrigerant;
2. Purify the pipeline with inert gas;
3. Vacuum;
4. Purify the pipeline with inert gas again;
5. Cut and replace the pipe or weld it.

The refrigerant should be recovered into a suitable cylinder. The system should be purged with oxygen-free nitrogen. This process may need to be repeated several times. Do not use compressed air or oxygen for this operation.

Procedure before pipe welding:

In the purging process, the system is filled with oxygen-free nitrogen to reach the working pressure under the vacuum state of the system, and then the oxygen-free nitrogen is discharged, and finally the system is evacuated. Repeat this process until all refrigerant in the system is removed. After filling the oxygen-free nitrogen for the last time, exhaust the gas to atmospheric pressure, and then the system is ready for welding. The above operations are necessary for pipeline welding operations.

Ensure that there is no ignition source near the outlet of the vacuum pump. Ensure good ventilation of the area.



Procedure of charging refrigerant

As a supplement for the conventional procedures, the following requirements have been added:

1. When using refrigerant charging equipment, avoid mutual contamination between different refrigerants. The pipeline of refrigerant filling should be as short as possible to reduce the residual amount of refrigerant;
2. When filling refrigerant, remove all fire sources near the unit;
3. Make sure that the refrigerant system is grounded before charging the refrigerant;
4. After charging refrigerant, stick label on the system;
5. Avoid excessive charge;

Perform a pressure test with oxygen-free nitrogen before charging refrigerant into the system. After charging, a leak test should be performed before the operation. The leak test should be performed again when leaving the area.

Scrapping

Before proceeding with this procedure, the technician should be aware of the equipment and all of its characteristics. It is mandatory to recover the refrigerant safe. If it is necessary to re-use the recovered refrigerant, samples of refrigerant and oil should be analyzed.

1. Before proceeding be aware of the equipment and its operation;
2. Disconnect the power supply;
3. Before proceeding with this procedure make sure that:

If necessary, the equipment of mechanical operation should be convenient to operate the refrigerant storage tank; All personal protective equipment is available, effective and is used correctly;

The entire recycling process should be done under the guidance of qualified persons; Recycling equipment and refrigerant storage tanks should meet the corresponding standards.



Maintenance safety

Warning

1. For repairs or scrapping, please contact the nearest or authorized service centre.
2. Repairs performed by unqualified personnel may be dangerous.
3. When charging the heat pump with R32 refrigerant and maintaining it, please strictly observe the manufacturer's requirements. This chapter mainly focuses on the special maintenance requirements of R32 refrigeration appliances. Please refer to the after-sales service manual for detailed maintenance operations.



Qualification requirements for maintenance personnel

1. All operating personnel or refrigeration circuit maintenance personnel should obtain a valid certificate issued by an evaluation body to determine that they have the qualifications for safe handling of refrigerants as required.
2. The maintenance and repair of the equipment can only be carried out in accordance with the method recommended by the equipment manufacturer. If other professionals are required to assist in maintaining and repairing the equipment, it should be carried out under the supervision of personnel qualified to use flammable refrigerants.

Site inspection

Before repairing heat pumps using R32 refrigerant, safety inspections must be carried out to ensure that the risk of fire is minimized. When servicing the refrigeration system, the following precautions should be observed before handling the system.

Operational procedure

Ensure that the risk from leakage of combustible gases or vapours is minimal during operations.

General operating area

All maintenance personnel and other personnel in the operation area should be aware of the character of the operation being performed. Avoid working in confined spaces. Work areas should be properly isolated to ensure safe working conditions without any combustible materials.

Check the presence of refrigerant

Refrigerant monitors should be used in the area before and during operations to ensure that technicians are aware of the presence of potentially combustible gases. Ensure that the leak detection equipment is suitable for R32 refrigerant, sparkles, fully sealed and intrinsically safe.

Fire extinguishers must be available in the room.

The applicable fire extinguisher should be located close to the cooling system or related components during hot working operations. The refrigerant injection area should be equipped with dry powder or carbon dioxide fire extinguisher.

No fire

Any fire sources should not be used when performing work related to exposed pipes containing R32 refrigerant. This may cause a fire or explosion hazard. All sources of fire, must be kept away from the area of installation, repair, removal and disposal of combustible refrigerants that may be released into the surrounding environment. Before starting operations, check the environment around the equipment to ensure that there is no danger of flammability or fire. There should be a "no smoking" sign.

Ventilated area

Ensure that the work area is open or fully ventilated before opening the system or performing thermal processing operations. Keep ventilation during operation. Ventilation will safely remove the leaked refrigerant.

Inspection of refrigeration equipment

If the electrical components are replaced, these should be installed in accordance with the purpose of use and correct operation regulations. Follow the manufacturer's maintenance and repair guidelines. If you have any questions, please consult the manufacturer's technical department. For installations using R32 refrigerant, the following inspection items apply:

1. The filling amount should be determined according to the marked amount on the heat pump's rating plate.
2. The ventilation equipment should operate normally, and the vents should be unobstructed.
3. If an indirect refrigeration cycle is used, please check whether there is refrigerant in the secondary circuit.
4. The logo or marking on the heat pump should be clearly visible, and the ambiguous signs and symbols should be corrected;
5. Refrigeration piping or electrical components should not be installed in corrosive environment.



- To avoid electrical shock, make sure to disconnect power supply 1 minute or more before operating. Even after 1 minute, always measure the voltage at the terminals of main circuit capacitors or electrical parts. Make sure that voltages are lower than the safety limits.
- Power supply wire line must be sized according to this manual and must be grounded.
- Don't put in hands to air outlet grill when fan is working.
- Don't touch wire lines with wet hand, and don't pull any wire lines of the unit.
- Water or any other kind liquid is forbidden to be poured onto the unit.
- Select correct circuit breaker and leakage protection switch.
- Don't touch the fins of source side heat exchanger, it may injure your hand.
- If any wire line is loose or damaged, contact qualified person to fix the problem.



AIR-WATER HEAT PUMP

1. Y-shape filter must be installed in front of water pump.
2. Required water flow – 0.18 m³/h for every 1kW capacity.
3. Power of the water pump must be matched to the resistance of installation components.
4. DHW utilize national standards urban tap water.
5. Install the temperature sensor on the water tank. Direct contact with water is not allowed.
6. When ambient temperature drops below 0°C, drain the water to prevent freezing (no need to drain systems with glycol).
7. A 40-70 mesh filter needs to be added before the inlet for the heat pump, and the water ion concentration needs to be less than 280 ppm.
8. Do not connect backup heater power supply directly to the heat pump. Install power contractor for the backup heater.
9. The installation must comply with above terms and conditions. If there are any deviations, the manufacturer is not responsible for the potential safety risks.

Important parts in heat pump

4.Heat pump installation and wiring

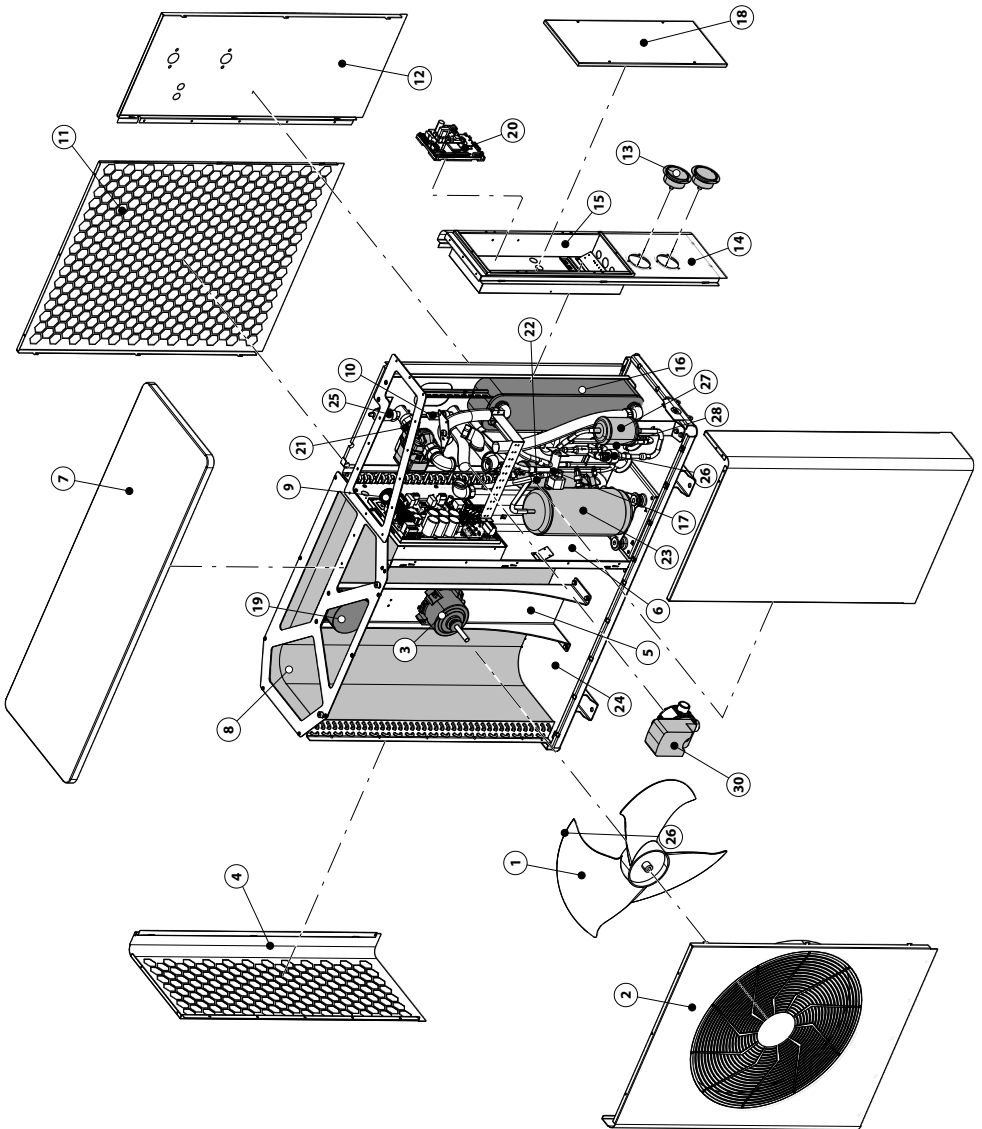

FGS10MB

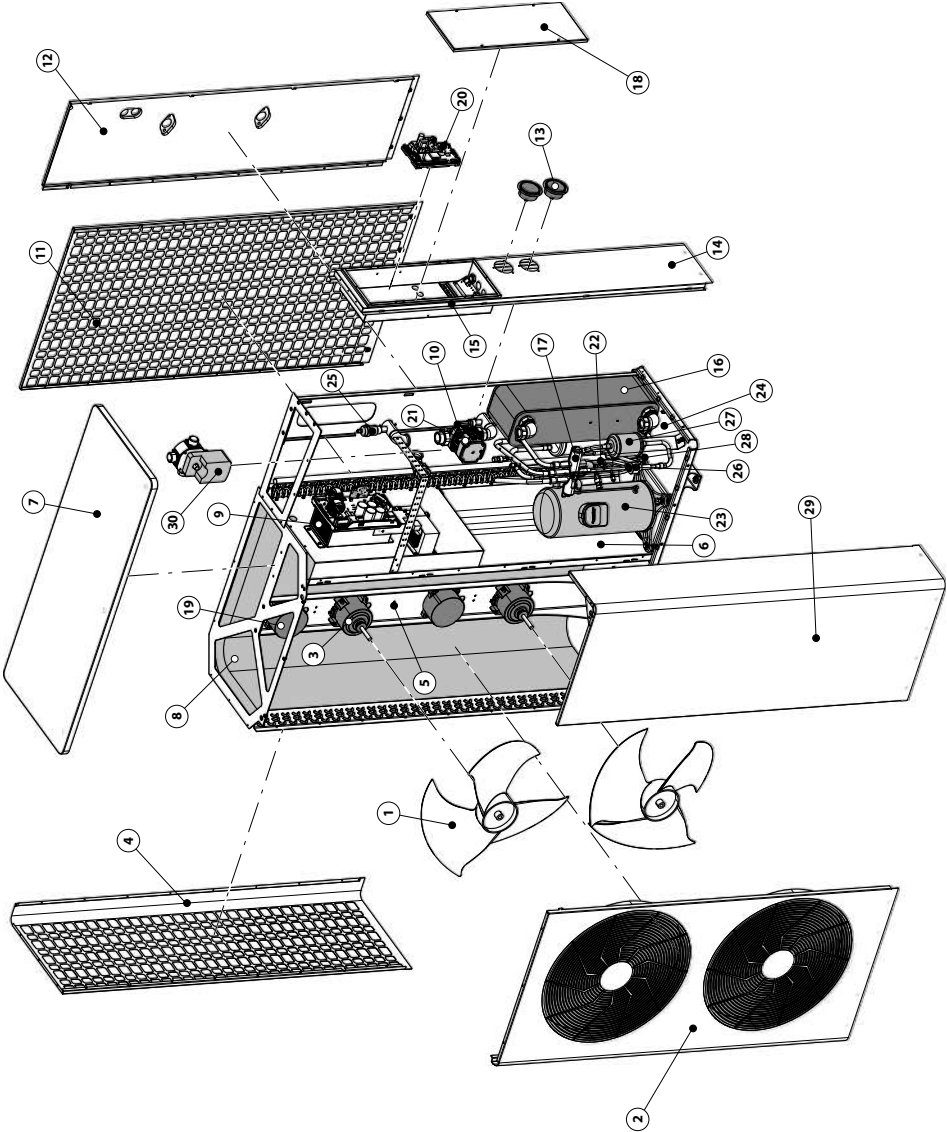

FGS20MB

FGS10MB

No.	Component	No.	Component
1	Air fan	16	Plate heat exchanger (condenser)
2	Air outlet panel	17	Four way valve
3	Fan motor	18	Electric box cover plate
4	Side wire mesh	19	Fan motor controller
5	Fan support	20	Controller
6	Middle panel	21	Water pump
7	Cover	22	Suction accumulator
8	Evaporator	23	Compressor
9	Compressor inverter	24	Chassis
10	Water flow switch	25	Automatic air vent
11	Rear wire mesh	26	Electronic expansion valve
12	Rear service panel	27	Filter dryer
13	Pressure gauges	28	Plate heat exchanger (economizer)
14	Right side panel	29	Front service panel
15	Controller box	30	Water flow reversing valve

FGS20MB

No.	Component	No.	Component
1	Air fan	16	Plate heat exchanger (condenser)
2	Air outlet panel	17	Four way valve
3	Fan motor	18	Electric box cover plate
4	Side wire mesh	19	Fan motor controller
5	Fan support	20	Controller
6	Middle panel	21	Water pump
7	Cover	22	Suction accumulator
8	Evaporator	23	Compressor
9	Compressor inverter	24	Chassis
10	Water flow switch	25	Automatic air vent
11	Rear wire mesh	26	Electronic expansion valve
12	Rear service panel	27	Filter dryer
13	Pressure gauges	28	Plate heat exchanger (economizer)
14	Right side panel	29	Front service panel
15	Controller box	30	Water flow reversing valve

HEAT PUMP SIZE

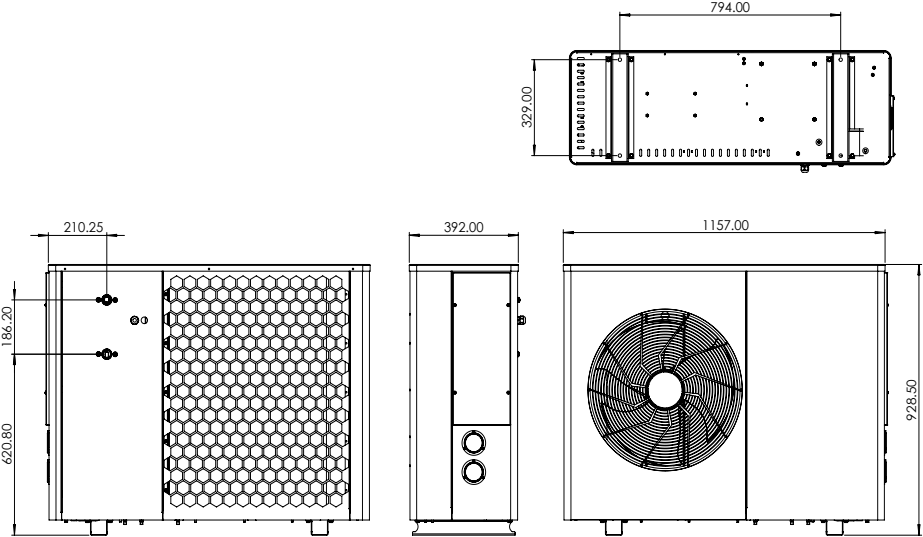

FGS10MB

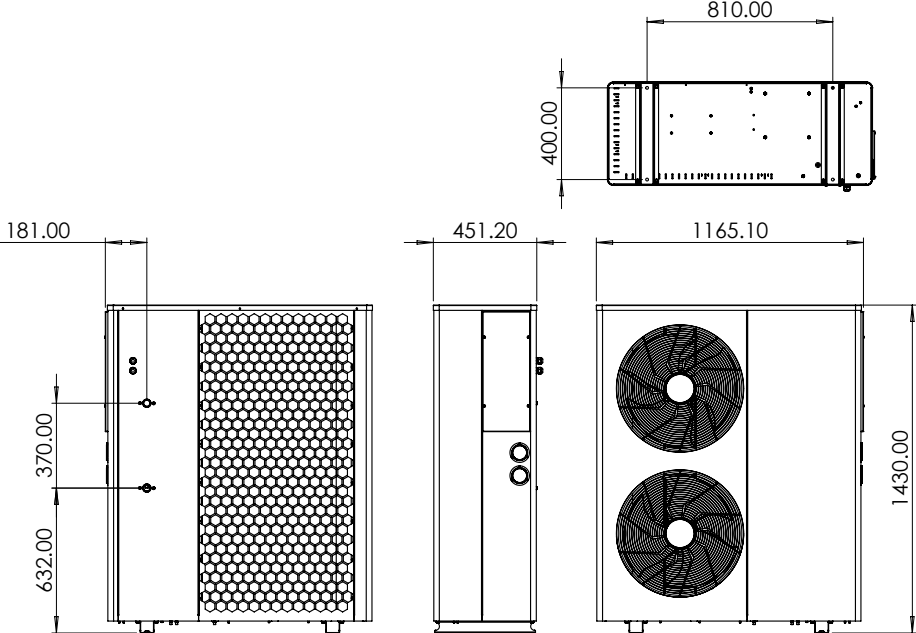

FGS20MB

INSTALLATION PLAN 1

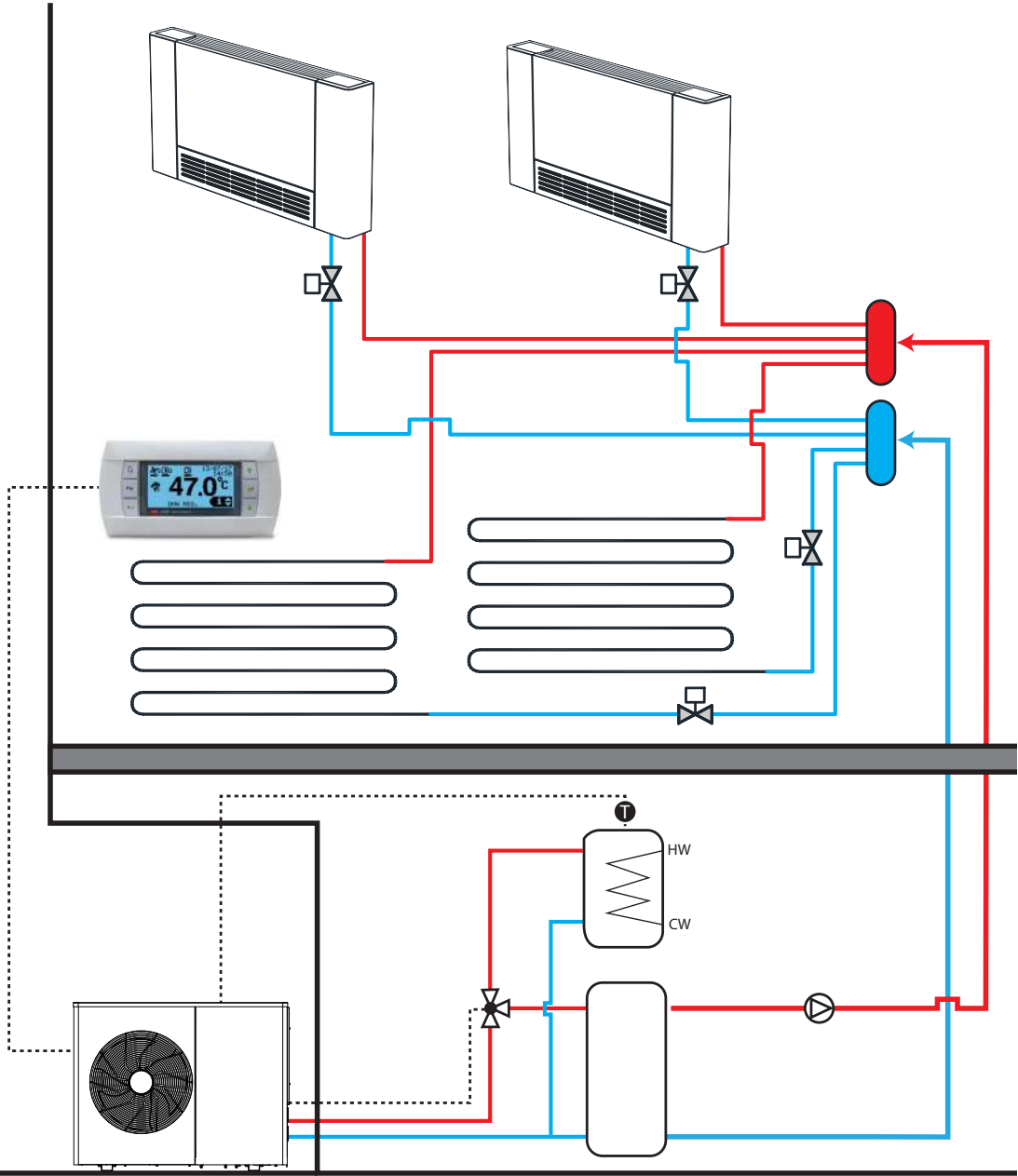

INSTALLATION PLAN 2

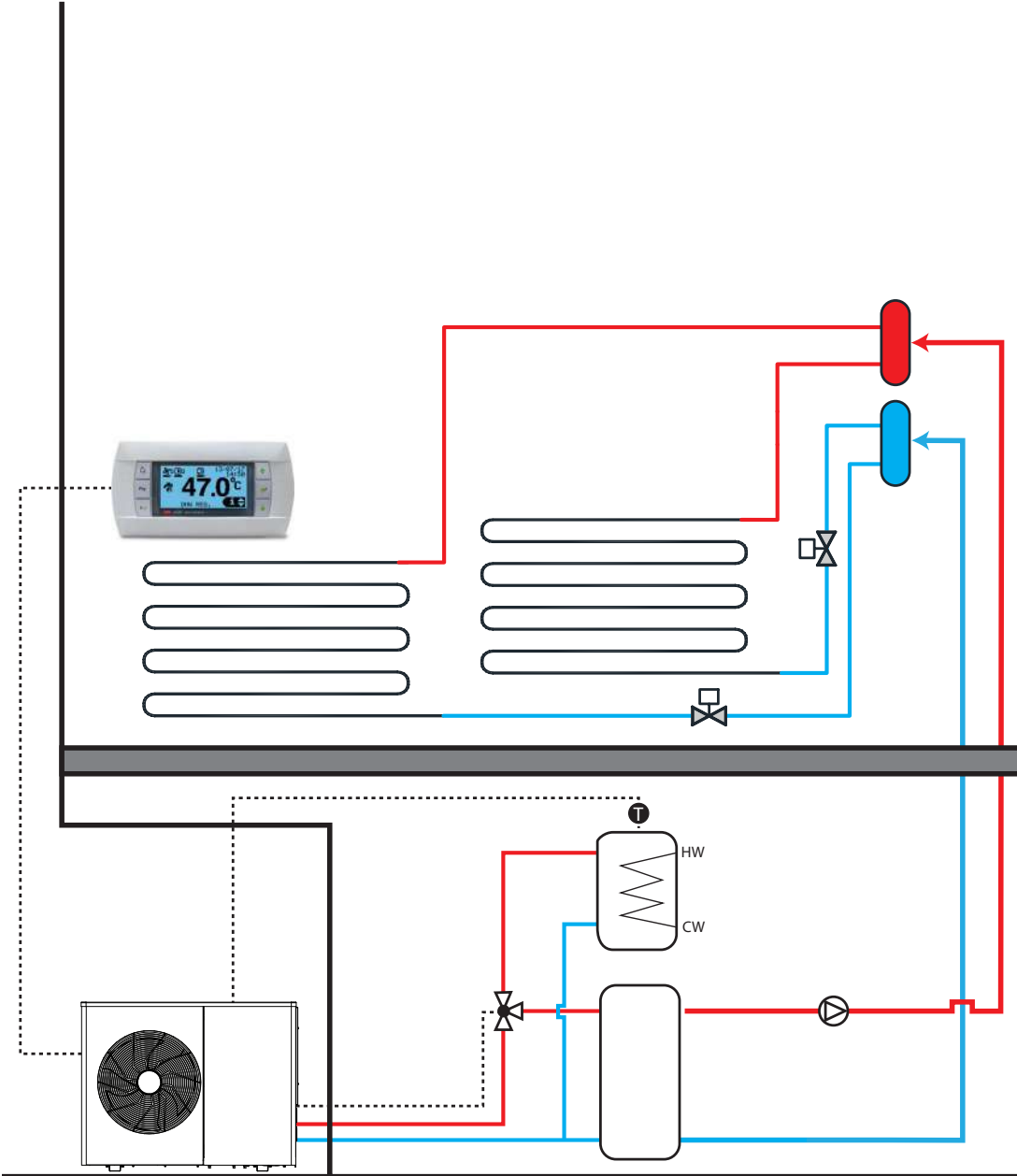

INSTALLATION PLAN 3

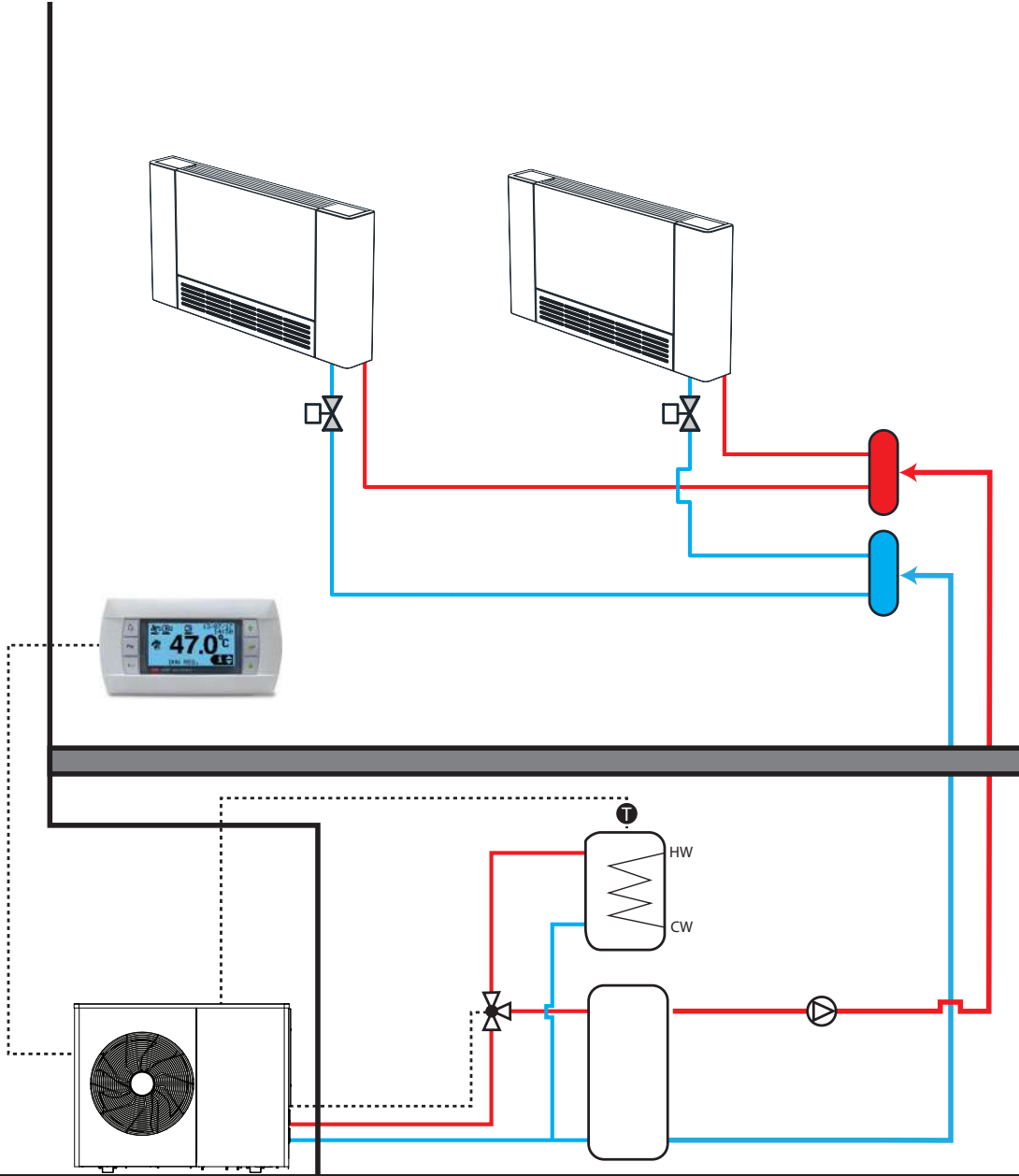

INSTALLATION PLAN 4

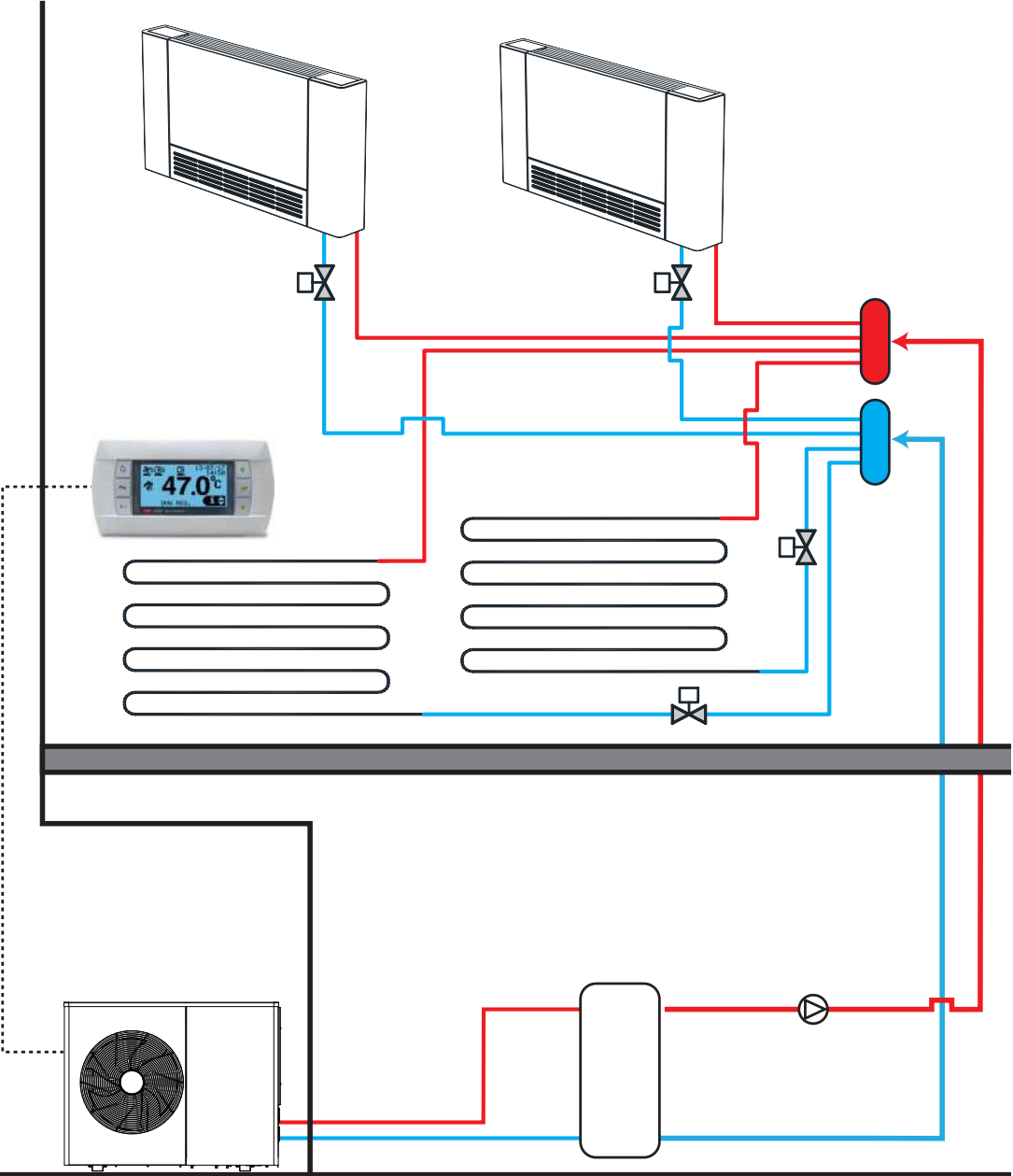

INSTALLATION PLAN HYBRID

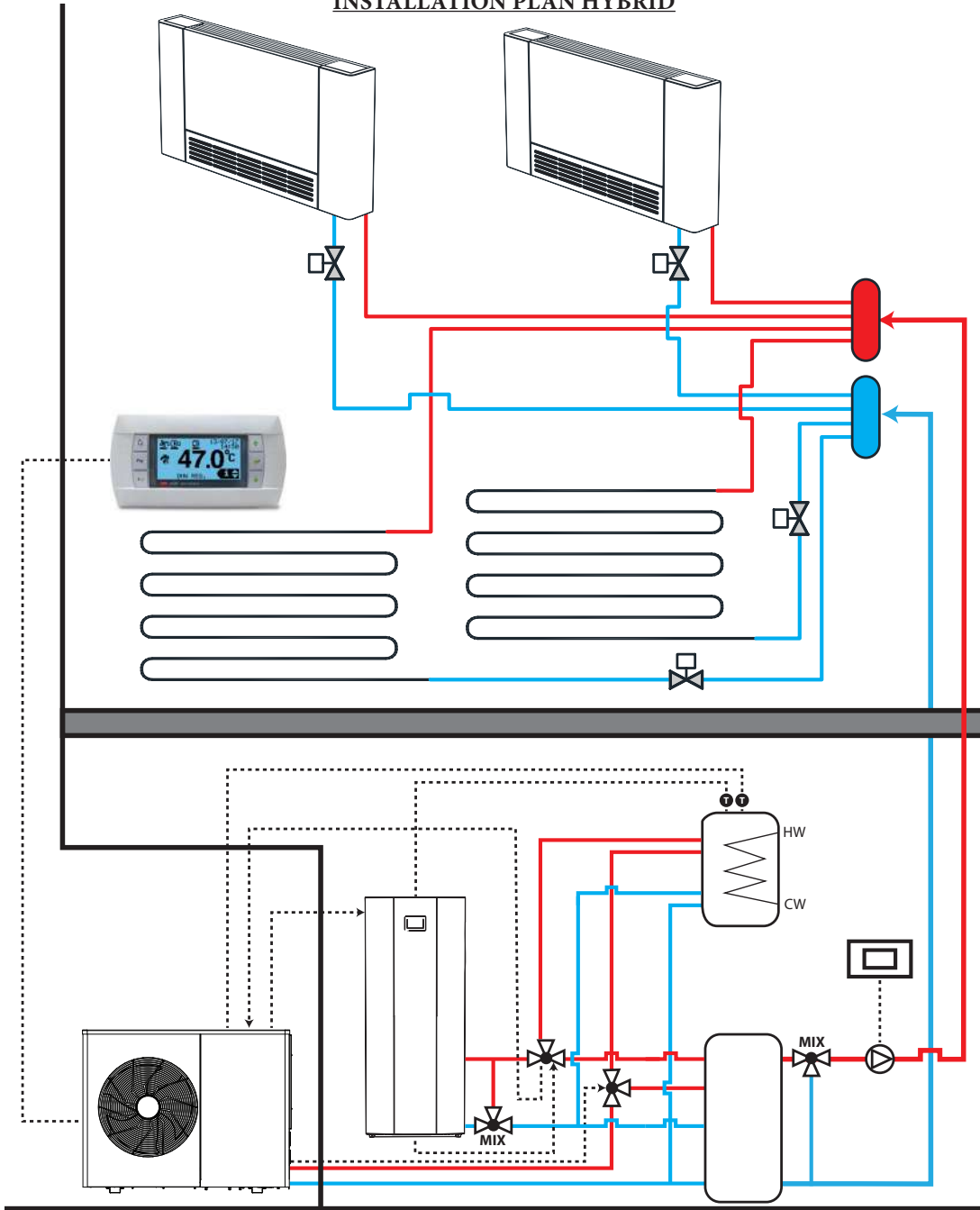

Heat pump installation notes

Warranty is not applicable in case of failure due to wrong installation.

Fixture and placement

- The heat pump must be installed in open space. Normally is installed on the roof of the building.
- The unit should be installed in dry and well-ventilated environment. If the humidity in the environment is high, electronic components may get corrosion or short circuit.
- Keep the distances around the unit according the drawing on page 16. Poor ventilated environment will cause lower efficiency, lower heating/cooling capacity, ice build on the heat exchanger, defrost cycle malfunction.
- Heat pump must be installed on flat concrete blocks, raised concrete platform or steel bracket (Fig.1,- Fig.2).
- The bottom of the heat pump must be at 200mm or more from the ground. Rain water or snow may enter inside if the installation is on ground. In a place where a large amount of snow can accumulate, the installation height must be considered.
- Installation of shed for the heat pump will protect the body and prevent snow cover the air outlet.
- Water drainage ditch should be set around the heat pump for condensate water and defrost cycle ice melting.
- Vibration absorbers should be installed.
- Always keep positive angle of installation according Fig. 3 . Negative angle will cause moisture in the compressor area.

Water connection

- The heat pump may only be used in closed hydraulic systems for space heating, space cooling and DHW production.
- Make sure that the water circuit is clean before installation. Flush the circuit if needed.
- The pressure in the water circuit should be higher than 1 bar.
- Check the system for leaks.
- Remove all the air from the system (Please check the air evacuation procedure). Check the leveling of the machine to avoid air trap (Fig.4)
- Circulating water pipe must be \geq DN25 (or PPR32). The water pipe diameter is critical for the water flow and the efficiency of the unit.
- Water resistance – ensure good water flow. (Please check the procedure for water flow check)
- Do not connect the unit direct to the hydraulics. Always connect the heat pump to buffer tank or hydraulic separator.
- Water pipes must be insulated. Not insulated pipes could cause loss of efficiency, risk of water freezing in cold wetter, water condensation in cooling mode.
- Always install water filter on the inlet water line (filtration 90-140 μ m). The heat pump is equipped with micro channel plate heat exchanger which can easily be damaged or blocked if there is no filter or an inappropriate filter is used.
- When install water temperature sensor on pipe (on water tank), make sure the sensor is not in direct contact with water.

Others:

- Do not install the heat pump in environment with corrosive, volatile, or flammable liquid or gas.
- Heat pump should far away from kitchen exhaust. The grease could damage the finned coil and reduce efficiency of the device.

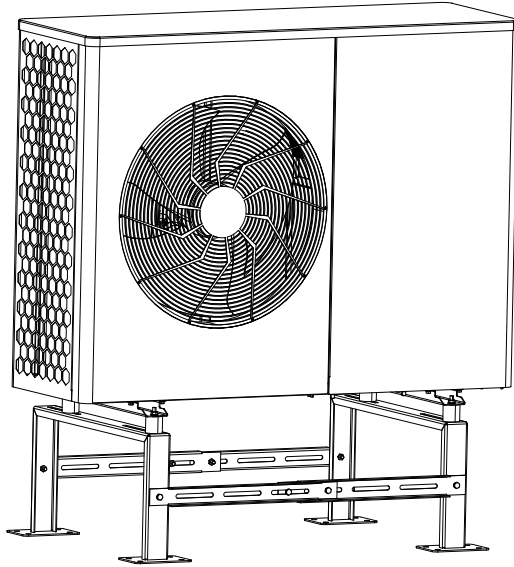

Fig. 1 Floor bracket with vibration absorber

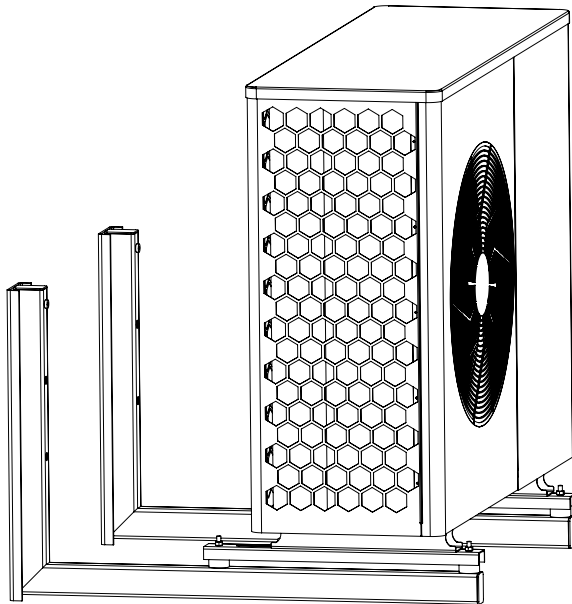

Fig. 1 Floor bracket with vibration absorber

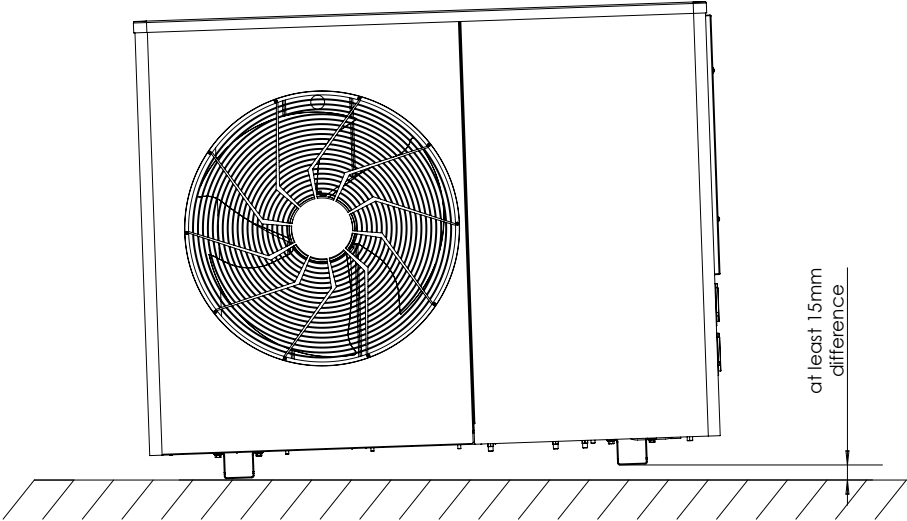

Fig. 3 Tilted angle

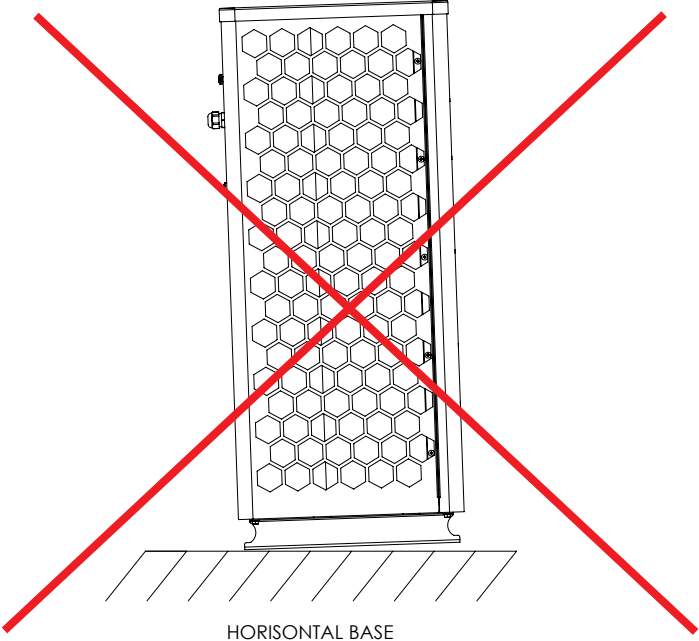
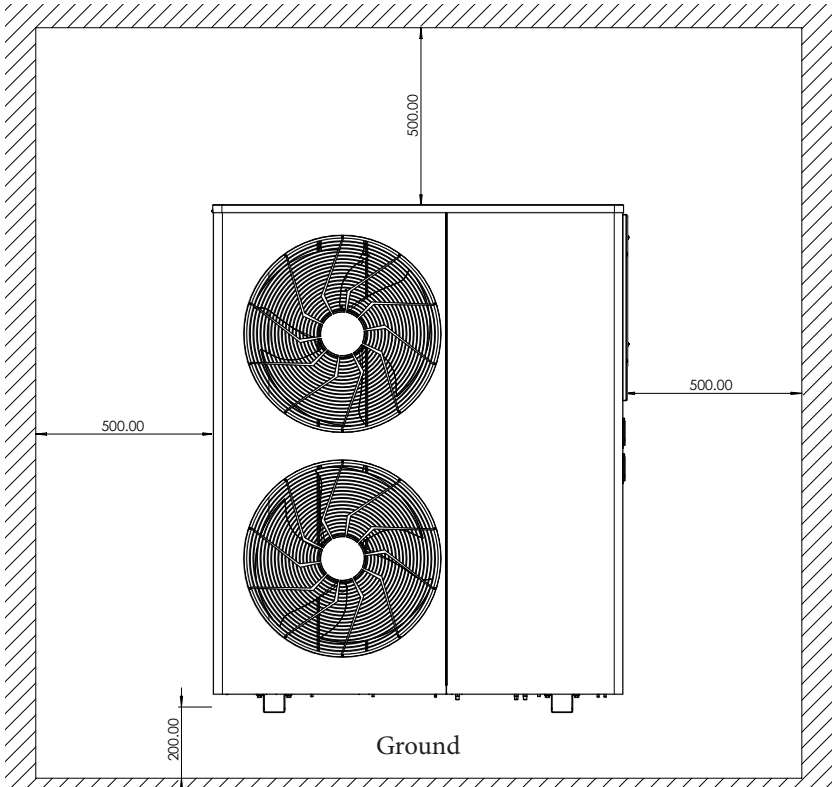
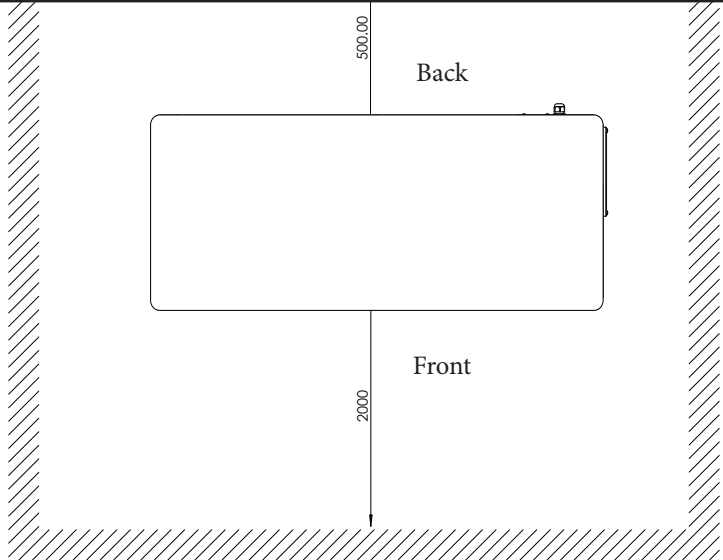

Fig. 4



Distances to barriers and the ground



Connection diagram 220 V (Voltage: 220 V 240 V/50 Hz or 60 Hz/1 Ph)

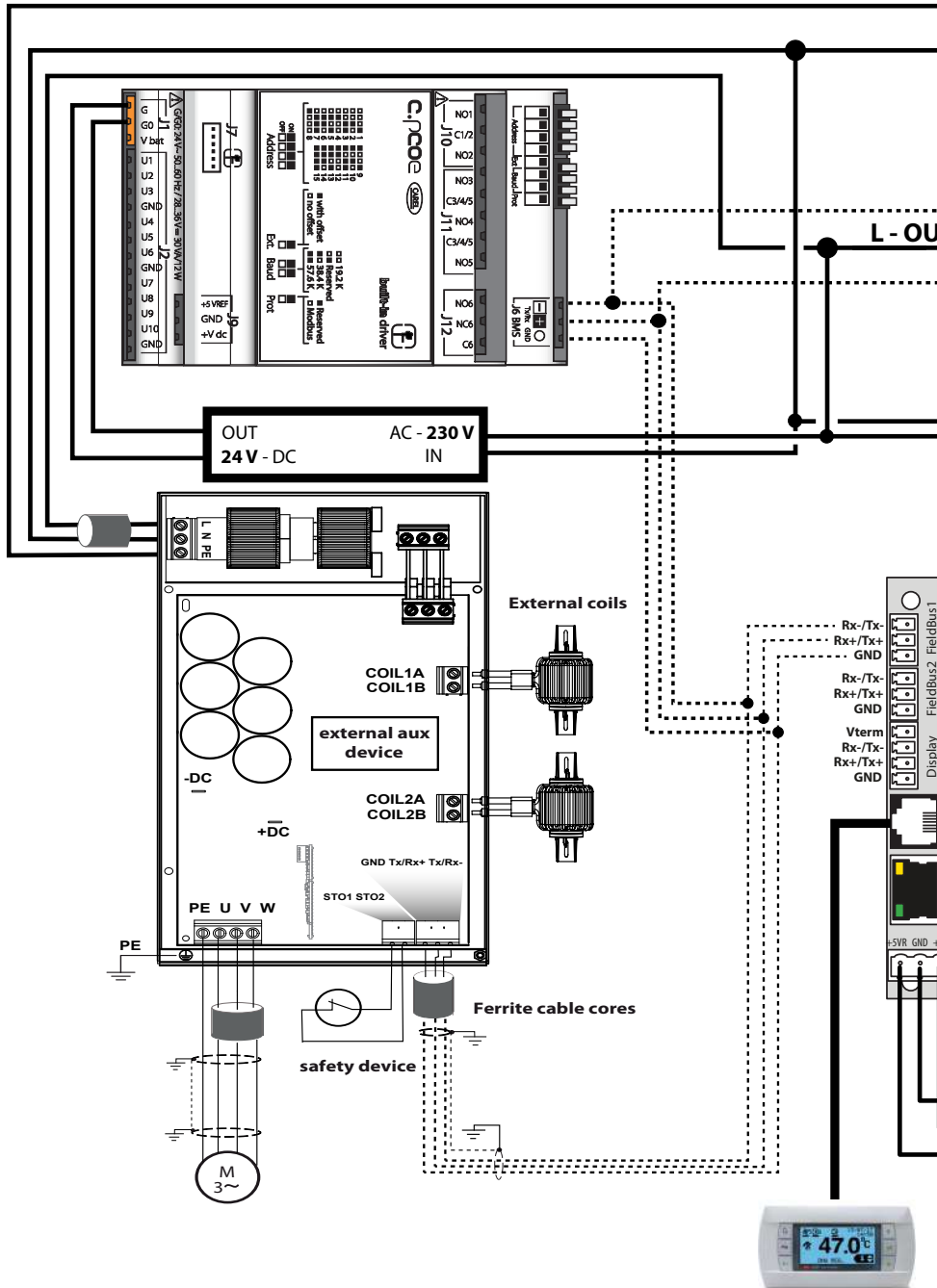

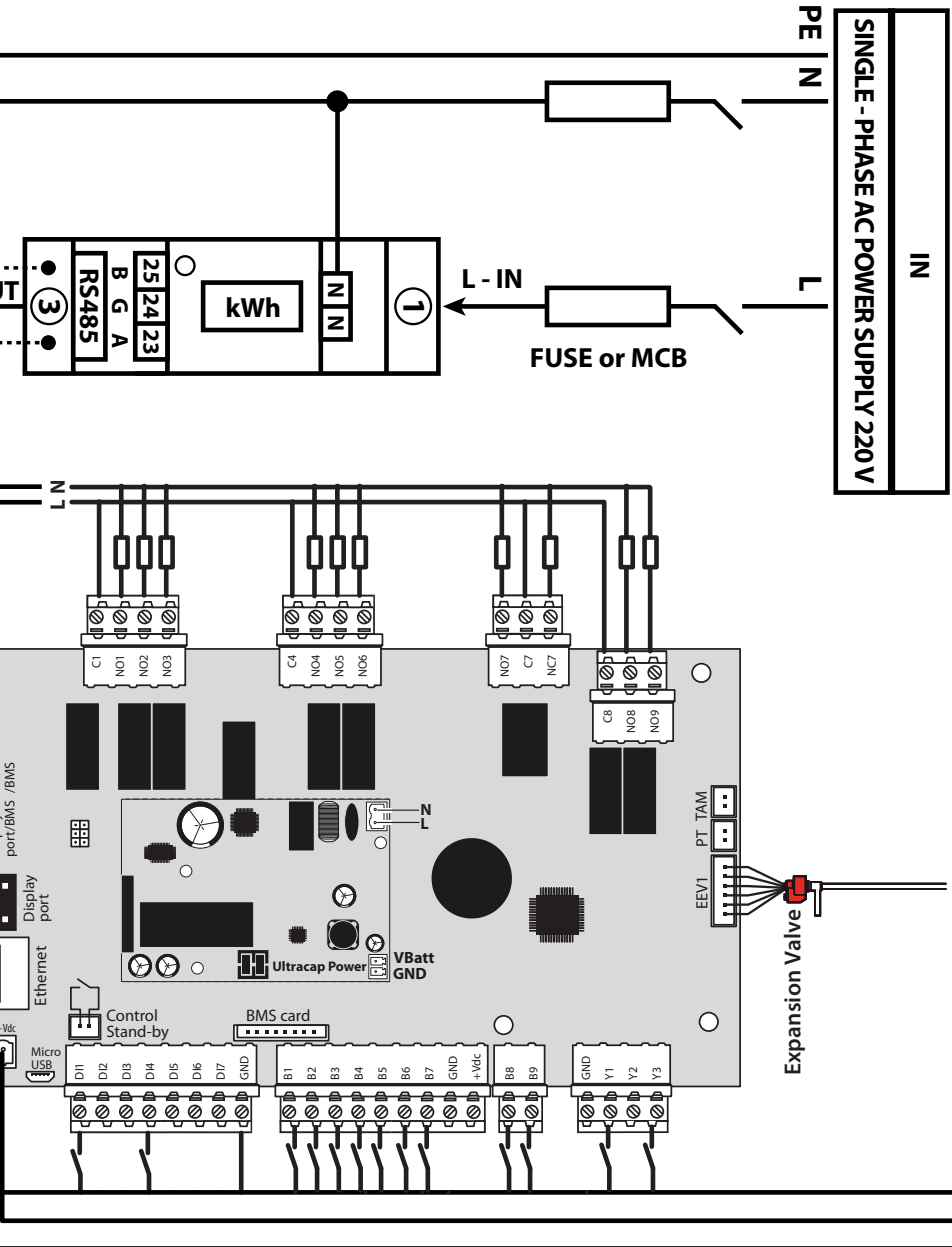

Connection diagram 380 V (Voltage: 380 V 420 V/50 Hz or 60 Hz/3 Ph)

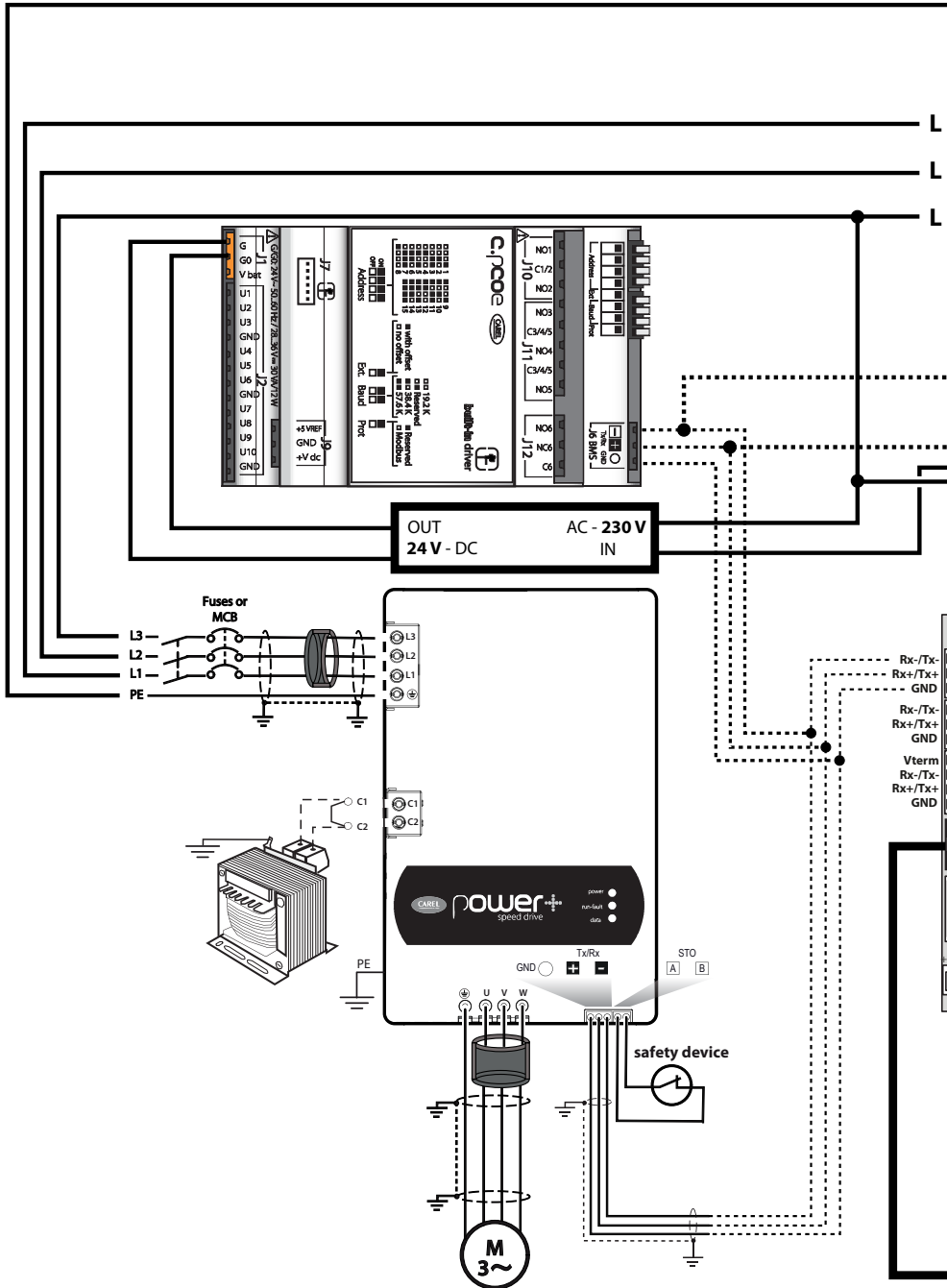

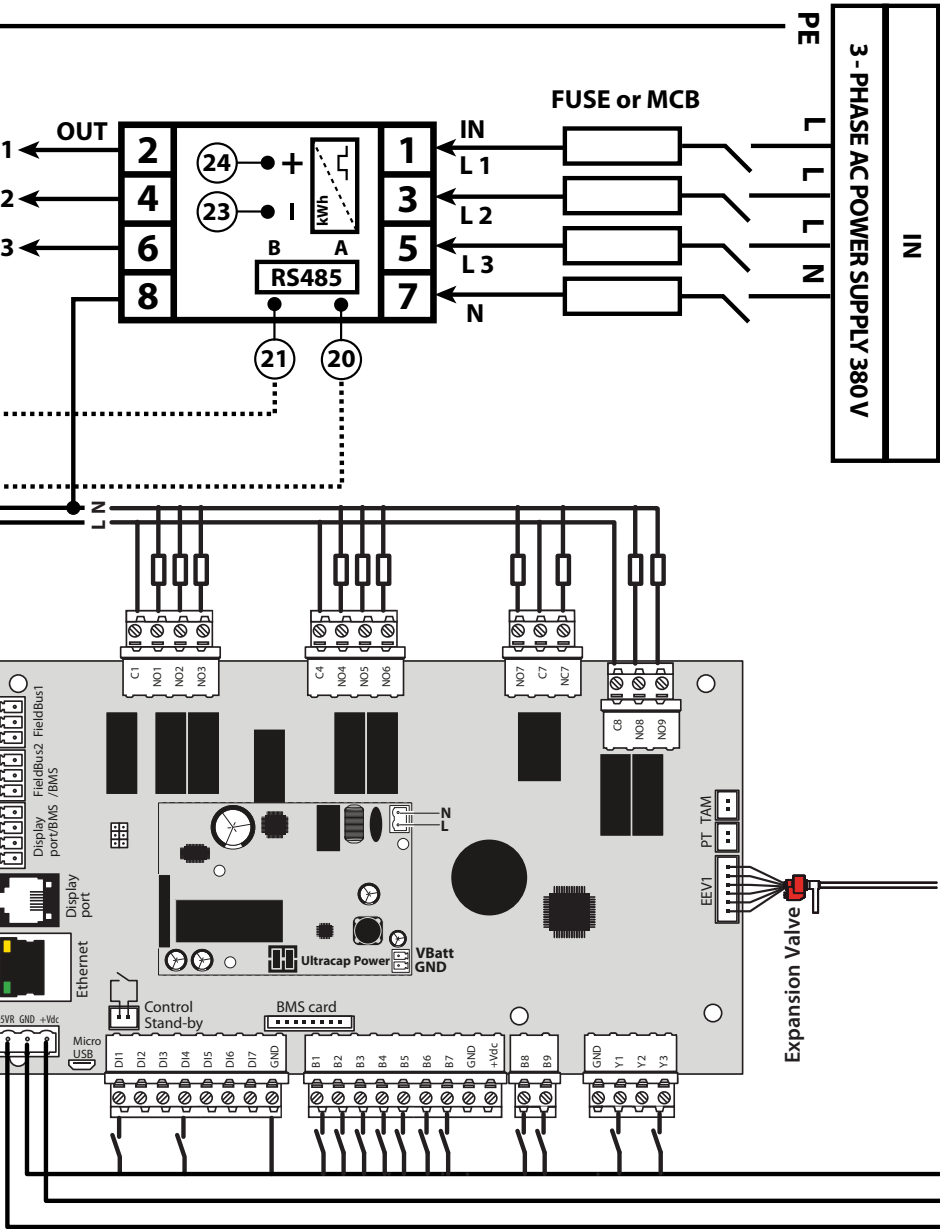

Terminals

L1	L2	L3	N	PE
-----------	-----------	-----------	----------	-----------

Power supply 380 - 420 V

		L	N	PE
--	--	----------	----------	-----------

Power supply 220- 240 V

Model	Line (mm2)	Max. Current(A)
FGS10MB	2.5	8.25
FGS20MB	4	14.48

FGS10MB

FGS20MB

Room Thermostat ON/OFF	Room Thermostat ON/OFF
Status boiler	Status boiler
DHW Temperature	DHW Temperature
GND	GND
Plant Heater N	Plant Heater N
Plant Heater L	Plant Heater L
DHW 3-way Valve N	DHW 3-way Valve N
DHW 3-way Valve L	DHW 3-way Valve L
DHW Heater N	DHW Heater N
DHW Heater L	DHW Heater L
Water Pump N	Water Pump N
Water Pump L	Water Pump L
L	L
N	N
L	L1
N	L2
PE	L3
	N
	PE

THE INSTALLATION MUST COMPLY WITH ABOVE TERMS AND CONDITIONS. IF THERE ARE ANY DEVI-







ATIONS, THE MANUFACTURER IS NOT RESPONSIBLE FOR THE POTENTIAL SAFETY RISKS.



Part 2. USER INTERFACE



2.1 Buttons

-  ENTER/MENU - Select row of quick access menu ; Switch from parameter display to setting ; Confirm value and move to next parameter.
-   UP/DOWN Scroll rows of quick access menu; Scroll between screens; Increase / decrease value
-  ALARM - - Display active alarms/mute buzzer; Reset alarms with manual reset (pressed and held)
-  Access the main menu (factory parameters)





2.2 Main mask

During the usual operation of the unit, the display will show:







- Devices status
- Working mode
- Scheduler
- Unit status
- Quick menu
- Regulation temperature
- Date and hour



1. Devices status - In this portion of the mask it's shown the actual devices status. The icon will be visible only if the device is enabled, the progress bar indicates the actual percentage. The devices available are shown as follows:

ICON	DESCRIPTION
	Source fan
	User pump
	DHW pump
	Compressor

2. Working mode - Depending on in which mode the unit it's regulating, it will be shown the connected icon to let the user know in which condition the unit it's working. The icons can be:

ICON	DESCRIPTION
	DHW only
	Heating only
	Cooling only
	DHW in configuration DHW + Heating
	DHW in configuration DHW + Cooling
	Defrost

3. Scheduler - The icon will be shown only in case of at least one of the two scheduler available is active.

4. Unit status - The unit status indicates the actual working phase of the unit, it can be:

TEXT	DESCRIPTION
STAND BY	The unit is in stand-by, waiting for enough request to switch on the regulating devices.
OFFbyALRM	The unit is forced off by a blocking alarm
OFFbyBMS	The unit is forced off by Supervision
OFFbyDI	The unit is forced off by digital input
OFFbyKEYB	The unit is forced off by keyboard
OFFbyChgOvr	L'unità è forzata in off per inversione di ciclo frigorifero The unit is forced off by changeover
SEASON CHG.	The unit is forced off by season change
PLANT REG.	The unit is working to satisfy the plant request
DHW REG.	The unit is working to satisfy the DHW request
DEFROST	The unit is in defrost phase.
SHUT DOWN	The unit is in shutdown phase
CYCL.INV.	The unit is in cycle inversion with the compressor kept on.

AFREEZE ADV	The unit is forced on for advanced antifreeze condition
ALARMS	The unit is in alarm status, but not blocking alarm the the entire unit.



5. Quick menu Using the "Up" and "Down" keys it's possible to select one of the two quick loops that are not password protected.

6. Regulation temperature. In this section it's shown the actual regulation temperature. This one can be different according to the unit and the actual working mode, the temperatures that can be shown are: 1 Plant return temperature 1 Plant supply temperature 1 Plant boiler temperature 1 Domestic How Water temperature

7. Date and hour In this section it's shown the actual date and hour setted in the controller.

2.3 User menu

Using the "Up" and "Down" keys it's possible to select one of the two quick loops that are not password protected. The quick loops available are:

ICON	DESCRIPTION
	Unit On/Off
	Informations
	Set

2.3.1 Informations

(THE USER MAY NOT BE ABLE TO FIND SOME OF THE MASKS. THE APPEARANCE DEPENDS ON THE SETTINGS)

Circuit information



1. Circuit request for thermoregulation
2. Status of the request processed
3. Envelope:

- Ok: zone within operating limits
- HiDP: High compression ratio
- HiDscgP: High condensing pressure
- HiCurr: High motor current
- HiSuctP: High suction pressure
- LoPRat: Low compressor ratio
- LoDP: Low differential pressure
- LoDscgP: Low condensing pressure
- LoSuctP: Low suction pressure

Compressor information

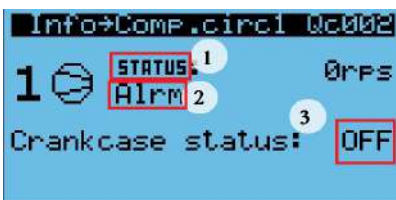

1. Current compressor speed (BLDC only)
2. Status of compressor :
 - Off (...s): off, indicating, if necessary, the remaining time before restarting
 - On (...s): on, indicating, if necessary, the remaining time before switching off
 - Man On: on manually
 - Man Off: off manually
 - Defr: on for defrost cycle
 - Alrm: off due to alarm.
3. Crankcase heater status

ExV information



1. Valve opening percentage
2. Valve opening steps
3. Valve status:
 - Init: driver initialization.
 - Close: valve closed
 - Off: valve in standby
 - Pos: valve in positioning
 - Wait: valve in activation
 - On: valve in regulation

- LoSH: Low superheat function running
 - LOP: Minimum evaporation temperature function running
 - MOP: Maximum evaporation temperature function running
4. Current set point
 5. Regulation values:
 - Suction superheat
 - Discharge superheat
 - Discharge temperature; the arrow indicates the reference value for the set point (i.e. what control is based on - suction SH, in the figure).

DHW heater Information



1. External temperature condition
2. Integration status:
 - None: No request active
 - Integration: Integration active together with the compressor
 - Substitution: Integration active in substitution of the compressor
 - Comp.Substitution: Integration active and compressor in alarm
 - Defrost: Integration active for Defrost condition
 - Antilegionella: Integration active for Antilegionella procedure (only if DHW Heater).
3. Device status:

Source information

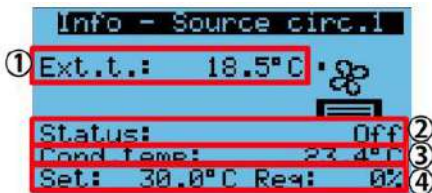

1. External temperature condition
2. Source fan status:
 - Off
 - On
 - Speed Up
 - Forced by defrost
 - Forced by prevent
 - Anti frost
 - Freecooling
 - Manual
 - Defrost

3. Saturated condensing temperature (or evaporating for chiller units).
4. Regulation setpoint and percentage of the request (the percentage will be shown only in case of modulating device).

Defrost information

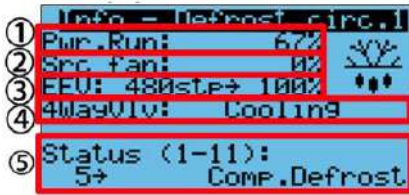

1. Circuit request for thermoregulation
2. Source fan status (the percentage of the fan request is on only present in case of modulating fans)
3. EEV position (in step and opening percentage)
4. 4 way valve status
5. Defrost status and description

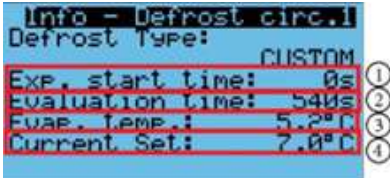

1. Time to start the defrost
2. Evaluation time
3. Difference between external temperature and evaporation temperature
4. Difference set point

DHW Information (3 way valve configuration)

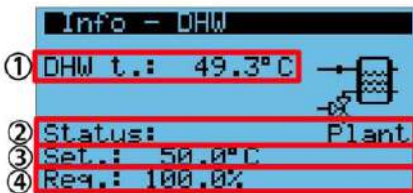

1. Domestic hot water temperature
2. 3 way valve status

- Plant
- DHW

3. Regulation set point
4. Percentage request

DHW Information (dedicated pump configuration)

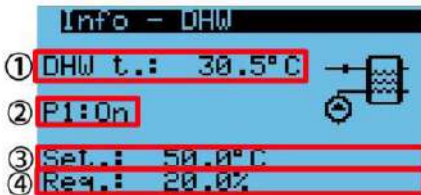

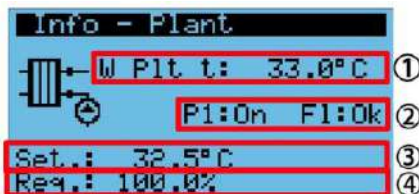

1. Domestic hot water temperature
2. DHW pump and flow switch status
3. Regulation setpoint
4. DHW request or DHW pump request if modulating pump

Plant information



1. Plant water temperature (in case of plant boiler regulation), plant inlet/outlet water temperature if available.
2. Flow switch and pump status
3. Regulation setpoint
4. Plant request or Plant pump request if modulating pump

Unit information

Info - Unit	
 DHW req:	0% ①
 Plant req:	78% ②
Unit req:	78% ③
Status:	Heating Req. ④

- OFFbyKEYB: unit in off by keyboard
- UstrPmpStrtUp: User pump start-up
- DHWPmpStrtUp: DHW pump start-up
- STANDby: Waiting switch on of the compressor
- CompStrtUp: compressor start-up
- CoolingReg: Unit in chiller regulation
- HeatingReg: Unit in heat pump regulation
- DHWReg: Unit in DHW regulation
- Rev.Cycle: Unit in cycle inversion status
- DefrostRUN: Unit in defrost
- AFreezeCHUsr: Plant pump antifreeze in chiller condition
- AFreezeHPUsr: Plant pump antifreeze in heat pump condition
- AFreezeAdvUsr: Plant advances antifreeze condition
- AFreezeCHSrc: Source pump antifreeze in chiller condition
- AFreezeHPSrc: Source pump antifreeze in heat pump condition
- ShutDown: Unit in shutdown
- Comp.Alarm: Compressor in alarm
- Circ.1Alarm: Circuit 1 in alarm
- UnitAlarm: Unit in alarm

1. DHW request
2. Plant request
3. Unit request
4. Unit regulation status:

Info→User PUMP 0c021	
Cond Temp.:	30.0°C ①
Cond Set.:	30.0°C ②
Cond Req.:	0.0% ③
Req.Status:	Off ④
DeltaT:	1.8°C ⑤
DeltaT Set.:	4.3°C ⑥
DeltaT Req.:	0.0% ⑦

1. Condensation temperature
2. Condensation set point
3. Condensation request
4. Regulation status
5. Difference between inlet and outlet water temperature
6. Difference set point
7. Difference request

Efficiency information (optional)

Info - eMeter Orno	
Voltage:	228.400V ①
Current:	0.745A ②
Power:	0kW ③

1. Voltage
2. Current
3. Power consumption

Info - COP	
Working mode:	Heating ①
Flow:	0.4m ³ /h ②
Consumption:	0kW ③
Heat. cap.:	0.0kW ④
COP/EER:	0.0/ ⑤

1. Work mode
2. Water flow rate
3. Total energy consumption
4. Heating/Cooling capacity
5. Coefficient of performance/ Energy efficiency ratio

On-Off



In this menu, it's possible to switch on or off the unit. The on status requires the following consensus:

- Keyboard from the On-Off menu
- Room thermostat (if enabled)
- Scheduler (if enabled)

Set



- In this menu it's possible to see and possibly change the current set temperatures.

Summer / Winter



- User has the possibility to change the working mode of the unit, from Summer to Winter and vice-versa.

Compressor limit



1. Limit enable checkbox.
2. Limit level
3. Time counter after limit switch
4. Limit level percentage

Set point compensation

The software adjusts the set point based on the outside temperature. Four points can be set for the outside temperature, with four corresponding points for the set point (number 1 is the current set point). The software calculates the set point based on the current outside temperature value and the lines defined by the points defined above. This function ensures better control than traditional linear compensation. In fact, an approximated climate curve can be defined based on the characteristics of the unit and the outside weather conditions. The configuration parameters are different in each of the three operating modes: Heating, Cooling and DHW. Compensation can be enabled separately in Cooling, Heating and DHW modes so as to allow complete control of the unit. In Heating and DHW modes, the lower the outside temperature, the higher the set point will be; in Cooling mode, on the other hand, the higher the outside temperature, the higher the set point will be.

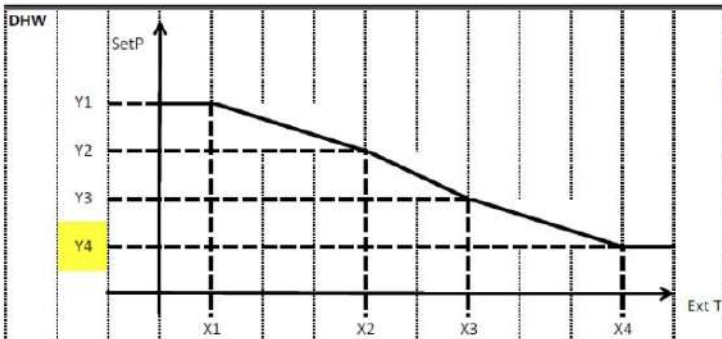
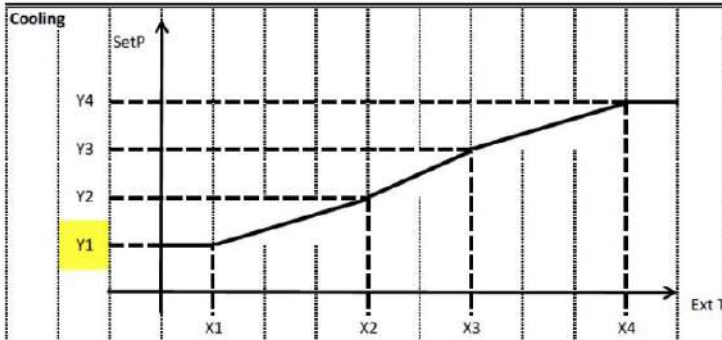

Example:

Heating

X4 = 0°C

Y4 = Heating set point = 35°C

X3 = -5°C

Y3 = 38°C

Outside temperature $\geq 0^\circ\text{C}$ -> Compensated set point = 35°C

Outside temperature = -2.5°C -> Compensated set point = 36.5°C

Outside temperature = -5°C -> Compensated set point = 38°C

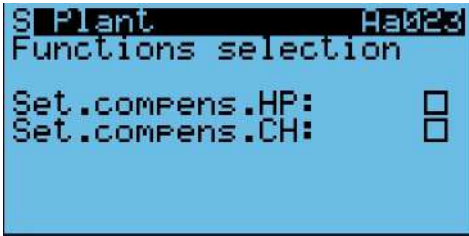

To enable the compensation function press PRG button > enter service password > A.Regulation > a.Plant > navigate with arrows to mask Aa023.

Check Set compens. HP to enable the compensation function in heating mode and Set compens. CH for cooling mode. New mask will appear for each mode (Aa024, Aa025).

SG ready (optional)



1. Boosted mode set point offset (operating mode 3)
2. Operating mode 4 set temperature
3. Signals and mode status
4. Current set point

Date/Time settings



To change the Time/Date settings press PRG button > set user password > navigate with arrows to H.Settings > a. Date/Time. In this mask the user can change the display format of the date, the date and hour.

Language

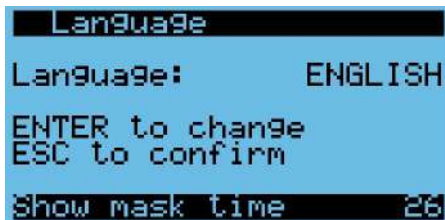

To change the language press PRG button > set user password > navigate with arrows to H.Settings > c.Language. In this mask the user can change the language by pressing enter and confirm with ESC.

Scheduler



To enable the scheduler press PRG button > set user password > navigate with arrows to F.Unit > c.Scheduler. In this mask the user can enable the scheduler.

ALARMS

- Pressing the ALARM key can occur in two different situations - no alarm or an alarm present.
- If there is no alarm, the following screen is displayed:



- This screen makes it possible to easily enter the alarms log using the ENTER key.
- If there is at least one alarm, the alarms screen is displayed sorted by alarm code from lesser to greater.

ALARM LOG



RESET ALARMS

The alarms can be reset manually, automatically or automatically with retries:

- Manual reset: when the cause of the alarm has stopped, the buzzer must first be reset using the ALARM button and then the ALARM button pressed a second time for a true reset. At this point, even the specific alarm action is reset and the device can restart.
- Automatic reset: when the alarm condition stops automatically, the buzzer is silenced and the alarm reset.
- Automatic reset with retries: The number of interventions per hour is checked. If that number is less than the set maximum, the alarm is on automatic reset, once the limit is exceeded it becomes manual.

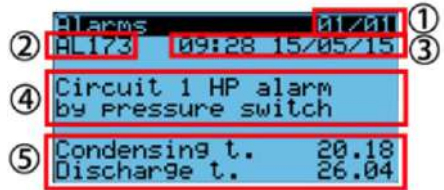

Each alarm contains the information needed to understand the cause of the alarm.

The information available in the screen is shown below:

1. Alarm number/total alarms
2. Unique alarm code
3. Alarm date and time
4. Long alarm description
5. Value of the probes linked to the alarm

In every alarm screen, the alarms log can be displayed by pressing ENTER.

The red LED under the ALARM button can be:

- Off: no active alarm
- Flashing: there is at least one active alarm and the display shows a screen that is not part of the alarms loop.
- On: there is at least one active alarms and a screen that is part of the alarms loop is displayed.

From the main menu, entering the Alarms Log menu allows access to the following alarms log display screen. The alarms log memorizes the software operation status when the alarms are triggered. Each log entry is an event that can be displayed from among all of the events available in the memory. The information saved in the alarms screen will also be saved in the alarms log. The maximum number of events that can be saved is 64. Once the limit is reached, the most recent alarm will overwrite the oldest one. The alarms log can be cleared in the Setting->Initialization menu through the specific command.

3. Maintenance and repairing

1. MAINTENANCE TIPS

The heat pump unit is a highly automated equipment. The unit status check is carried out regularly during use. If the unit can be maintained and maintained for a long time and effectively, the unit's operational reliability and service life will be unexpectedly improved.

1. Users should pay attention to the use and maintenance of this unit: all safety protection devices in the unit are set before leaving the factory, do not adjust by yourself;
2. Always check whether the power supply and electrical system wiring of the unit is firm, whether the electrical components are malfunctioning, and if necessary, repair and replace them in time;
3. Always check the water system's hydration, the water tank safety valve, the liquid level controller and the exhaust device to work properly, so as to avoid the air circulation into the system and reduce the water circulation, thus affecting the unit's heating capacity and unit operation reliability;
4. The unit should be kept clean and dry and well ventilated. Regularly clean (1-2 months) air-side heat exchangers to maintain good heat transfer;
5. Always check the operation of each component of the unit, check the oil pipe at the pipe joint and the gas valve, and ensure that the refrigerant of the unit is not leaking;
6. Do not stack any debris around the unit to avoid blocking the air inlet and outlet. The unit should be clean and dry and well ventilated.
7. If the downtime is long, the water in the unit piping should be drained, and the power supply should be cut off and the protective cover should be placed. When running again, check the system thoroughly before starting up;
8. If the unit fails and the user cannot solve the problem, please inform the company's special maintenance department in order to send someone to repair it in time;
9. Clean water filter regularly
10. While fouling on the plate heat exchangers, back flushing is always possible to remove most of the soft debris that is blocking the inside. Weak acids with concentration less than 5%; for example: citric acid, oxalic acid add in a tank. Circulate the cleaning solvent through BPHE and flush thoroughly with clean fresh water. Before restarting the system, flush the plate heat exchanger with large amounts of fresh water to purge any remaining acid solution. If the acidity is too high, the copper and stainless steel inside the BPHE may be etched or corroded.

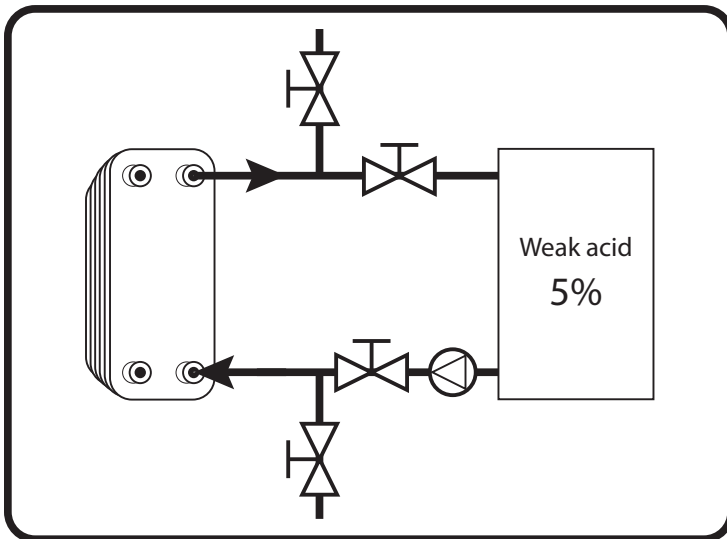

2. ERROR INPUT AND PROTECTION ALARM

Code and Description	Type	Effect
AL001 Unit - Remote alarm	User reset	Switch off unit
AL002 Unit - Error in the number of retain memory writings	User reset	Only indication
AL003 Unit - Error in retain memory writings	User reset	Only indication
AL004 Unit - User inlet water temperature probe	Auto reset	Switch off user regulation
AL005 Unit - User outlet water temperature probe	Auto reset	Switch off user regulation
AL007 Unit - External temperature probe	Auto reset	Only indication
AL008 Unit - User pump 1 overload	User reset	Switch off user regulation
AL010 Unit - Flow switch alarm, no flow present with user pump 1 active	Auto reset until: 5 times in 3600s	Switch off user regulation
AL012 Unit - User pump group alarm	User reset	Switch off user regulation
AL014 Unit - User 1 pump maintenance	Auto reset	Only indication
AL016 Unit - High chilled water temperature	Auto reset	Only indication
AL017 Unit - Low plant water temperature	Auto reset	Only indication
AL018 Unit - Low DHW water temperature	Auto reset	Only indication
AL019 Unit - Alarm antifreeze advanced in HP mode	Auto reset	Indication and forcing on unit
AL020 Unit - DHW temperature probe	Auto reset	Switch off DHW regulation
AL022 Unit - Plant temperature probe alarm	Auto reset	Switch off user regulation
AL023 Unit - Generic source alarm	Auto reset until: 3 times in 3600s	Switch off unit
AL024 Unit - DHW 1 pump maintenance	Auto reset	Only indication
AL025 Unit - DHW pump group alarm Switch off	User reset	DHW regulation
AL029 Unit - Alarm user antifreeze by water temperature in chiller mode	Auto reset	Switch off compressor, forced on user pump
AL030 Unit - Alarm user antifreeze by water temperature in heat pump mode	Auto reset	Forced on user pump
AL092 Circuit 1 - Defrost interrupted by a circuit alarm	Auto reset	Only indication
AL093 Circuit 1 - Alarm discharge probe pressure	Auto reset	Switch off circuit 1
AL094 Circuit 1 - Alarm suction probe pressure	Auto reset	Switch off circuit 1
AL095 Circuit 1 - Alarm discharge probe temperature	Auto reset	Switch off circuit 1
AL096 Circuit 1 - Alarm suction probe temperatu	Auto reset	Switch off circuit 1
AL098 Circuit 1 Envelope - High compression ratio	Auto reset	Switch off circuit 1
AL099 Circuit 1 Envelope - High discharge pressure	Auto reset until: 3 times in 3600s	Switch off circuit 1
AL100 Circuit 1 Envelope - High motor current	Auto reset	Switch off circuit 1
AL101 Circuit 1 Envelope - High suction pressure	Auto reset	Switch off circuit 1
AL102 Circuit 1 Envelope - Low compression ratio	Auto reset	Switch off circuit 1
AL103 Circuit 1 Envelope - Low differential pressure	Auto reset	Switch off circuit 1
AL104 Circuit 1 Envelope - Low discharge pressure	Auto reset	Switch off circuit 1
AL105 Circuit 1 Envelope - Low suction pressure	Auto reset	Switch off circuit 1
AL106 Circuit 1 Envelope - High discharge temperature	Auto reset	Switch off circuit 1

Code and Description	Type	Effect
AL107 Circuit 1 EVD - Low SH	Auto reset until: 3 times in 3600s	Switch off circuit 1
AL108 Circuit 1 EVD - LOP	Auto reset	Switch off circuit 1
AL109 Circuit 1 EVD - MOP	Auto reset	Switch off circuit 1
AL110 Circuit 1 EVD - High condensing temperature	Auto reset	Switch off circuit 1
AL111 Circuit 1 EVD - Low suction temperature	Auto reset	Switch off circuit 1
AL112 Circuit 1 EVD - Motor error	User reset	Switch off circuit 1
AL113 Circuit 1 EVD - Emergency closing	Auto reset	Switch off circuit 1
AL114 Circuit 1 EVD - Setting out of bound	Auto reset	Switch off circuit 1
AL115 Circuit 1 EVD - Settings range error	Auto reset	Only indication
AL116 Circuit 1 EVD - Offline	Auto reset	Switch off circuit 1
AL119 Circuit 1 EVD - Incomplete valve closing	Auto reset	Switch off circuit 1
AL122 Circuit 1 Inverter - Offline Switch off	Auto reset	Power+ circuit 1
AL123 Circuit 1 Inverter - Drive overcurrent (01)	Auto reset	Switch off Power+ circuit 1
AL124 Circuit 1 Inverter - Motor overload (02)	Auto reset	Switch off Power+ circuit 1
AL125 Circuit 1 Inverter - DC Bus overvoltage (03)	Auto reset	Switch off Power+ circuit 1
AL126 Circuit 1 Inverter - DC bus undervoltage (04)	Auto reset	Switch off Power+ circuit 1
AL127 Circuit 1 Inverter - Drive overtemperature (05)	Auto reset	Switch off Power+ circuit 1
AL128 Circuit 1 Inverter - Drive undertemperature (06)	Auto reset	Switch off Power+ circuit 1
AL129 Circuit 1 Inverter - HW overcurrent HW (07)	Auto reset	Switch off Power+ circuit 1
AL130 Circuit 1 Inverter - PTC motor overtemperature (08)	Auto reset	Switch off Power+ circuit 1
AL131 Circuit 1 Inverter - IGBT module error (09)	Auto reset	Switch off Power+ circuit 1
AL132 Circuit 1 Inverter - CPU error (10)	Auto reset	Switch off Power+ circuit 1
AL133 Circuit 1 Inverter - Parameter default (11)	Auto reset	Switch off Power+ circuit 1
AL134 Circuit 1 Inverter - DC bus ripple (12)	Auto reset	Switch off Power+ circuit 1
AL135 Circuit 1 Inverter - Data communication fault (13)	Auto reset	Switch off Power+ circuit 1
AL136 Circuit 1 Inverter - Drive thermistor fault (14)	Auto reset	Switch off Power+ circuit 1
AL137 Circuit 1 Inverter - Autotuning fault (15)	Auto reset	Switch off Power+ circuit 1
AL138 Circuit 1 Inverter - Drive disabled (16)	Auto reset	Switch off Power+ circuit 1
AL139 Circuit 1 Inverter - Motor phase fault (17)	Auto reset	Switch off Power+ circuit 1
AL140 Circuit 1 Inverter - Internal fan fault (18)	Auto reset	Switch off Power+ circuit 1
AL141 Circuit 1 Inverter - Speed fault (19)	Auto reset	Switch off Power+ circuit 1
AL142 Circuit 1 Inverter - PFC module error (20)	Auto reset	Switch off Power+ circuit 1
AL143 Circuit 1 Inverter - PFC overvoltage (21)	Auto reset	Switch off Power+ circuit 1
AL144 Circuit 1 Inverter - PFC undervoltage (22)	Auto reset	Switch off Power+ circuit 1
AL145 Circuit 1 Inverter - STO detection error (23)	Auto reset	Switch off Power+ circuit 1
AL146 Circuit 1 Inverter - STO detection error (24)	Auto reset	Switch off Power+ circuit 1
AL147 Circuit 1 Inverter - Ground fault (25)	Auto reset	Switch off Power+ circuit 1
AL148 Circuit 1 Inverter - ADC conversion sync fault (26)	Auto reset	Switch off Power+ circuit 1

Code and Description	Type	Effect
AL149 Circuit 1 Inverter - HW sync fault (27)	Auto reset	Switch off Power+ circuit 1
AL150 Circuit 1 Inverter - Drive overload (28)	Auto reset	Switch off Power+ circuit 1
AL151 Circuit 1 Inverter - Error code (29)	Auto reset	Switch off Power+ circuit 1
AL152 Circuit 1 Inverter - Unexpected restart (98)	Auto reset	Switch off Power+ circuit 1
AL153 Circuit 1 Inverter - Unexpected stop (99)	Auto reset	Switch off Power+ circuit 1
AL154 Circuit 1 BLDC - Starting failure Switch off	User reset	Power+ circuit 1
AL155 Circuit 1 BLDC - Delta pressure greater than the allowable at startup	Auto reset	Switch off Power+ circuit 1
AL159 Circuit 1 - User alarm freeze evaporation temperature until: 3 times in 3600s	Auto reset	Switch off circuit 1
AL160 Circuit 1 - Compressor 1 maintenance	Auto reset	Only indication
AL163 Circuit 1 - Source fan 1 circuit 1 maintenance	Auto reset	Only indication
AL166 Circuit 1 - High pressure alarm by pressure switch	Auto reset until: 3 times in 3600s	Switch off circuit 1
AL167 Circuit 1 - Low pressure alarm by pressure switch	Auto reset until: 3 times in 3600s	Switch off circuit 1
AL168 Circuit 1 - Overload compressor 1	User reset	Switch off compressor 1 circuit 1
AL308 Circuit 1 - Alarm Safe 101 - 116	Auto reset	Switch off Power+ circuit 1
AL324 Circuit 1 - Alarm Safe 201 - 216	Auto reset	Switch off Power+ circuit 1
AL372 Unit - Plant heater	maintenance Auto reset	Only indication
AL373 Unit - DHW heater maintenance	Auto reset	Only indication

3. OTHER PROBLEM AND REPAIRING

No	Error	Possible reason	Method
1	Heat pump doesn't run	1. Power supply cable is loose 2. The fuse of power supply is fused.	1. Cut off the power supply to check and repair. 2. Change the fuse.
2	Low heating capacity	1. Refrigerant is not enough 2. Poor water circuit insulation 3. Dirty air heat exchanger 4. Water heat exchanger scaled	1. Check for leakage, repair, charge refrigerant 2. Improve the insulation 3. Clean air heat exchanger 4. Clean water heat exchanger
3	Compressor not running	1. Power supply error 2. Loose cable connection 3. Compressor overheated	1. Check reason and solve 2. Check loose and repair 3. Check reason and repair
4	Compressor noise too loud	1. Expansion valve damage lead to liquid entering compressor 2. The internal parts of compressor damaged 3. Compressor lack of oil	1. Change expansion valve 2. Change compressor 3. Compensate oil amount
5	Fan motor not running	1. Fan blade fixing screw is loose 2. Fan motor damaged 3. Fan motor controller damaged	1. Tight the screw 2. Change fan motor 3. Change the controller
6	Compressor runs, but doesn't heat	1. Compressor damaged	1. Change compressor



MARELI SYSTEMS

Industrial Zone Simitli,
2730 Region Blagoevgrad
Bulgaria

info@mareli-systems.com
www.mareli-systems.com

MARELI SYSTEMS disclaims any responsibility for possible inaccuracies contained in this manual if they are due to printing or transcription errors. We reserve the right to make any change that appears to be necessary or useful without harm the essential characteristics
